

Large Capacity

Blixers®



Blixer® 45 -
47 Qt. Capacity

Blixer® 60 -
63 Qt. Capacity



Designed for Vertical Cutting
and Mixing: Mix, Chop,
Puree, Blend.



- All stainless steel machine.
- Adjustable 2-blade BLIXER® knife assembly gives equal results for small or large batches.
- Bowl is easily removed for cleaning.
- Bowl tilts for easy removal of product.
- Polycarbonate lid designed to allow the addition of liquids or ingredients during processing.
- Lid comes equipped with a wiper assembly to clean sides of bowl and lid.
- Digital timer for better preparation control.
- Stainless steel bowl and frame designed to be simple to use and to clean.
- Delivered with stainless steel bowl (Blixer 45 - 47 Qt., Blixer 60 - 63 Qt.) and 2 blade serrated BLIXER® knife assembly.
- 1 year parts and labor warranty/on site service.



Robot Coupe U.S.A., Inc.
P.O. Box 16625
Jackson, MS 39236-6625
1-800-824-1646 • (601) 898-8411
FAX: (601) 898-9134
www.robotcoupeusa.com • e-mail: info@robotcoupeusa.

Specifications

STANDARD MODEL:

Blixer 45: 47 stainless steel bowl and 2 blade serrated Blixer knife assembly.

Blixer 60: 63 stainless steel bowl and 2 blade serrated Blixer knife assembly.

ELECTRICAL REQUIREMENTS:

Blixer 45: 208-240V, 60Hz, 35 Amps, three phase.

Blixer 60: 208-240V, 60Hz, 45 Amps, three phase.

Contact your local electrician for local code requirements.

SAFETIES: Comply with electrical standard ETL, cETL, toUL763. Magnetic safety and thermal protection, bowl detection device, bowl detection in vertical position device, lid detection device and locking lid detection devices.

MOTOR:

Blixer 45: 6 HP, 1800 and 3600 rpm, three phase

Blixer 60: 7 HP, 1800 and 3600 rpm, three phase

WEIGHT:

Blixer 45: 434 lbs Approx. Shipping Weight

Blixer 60: 443 lbs Approx. Shipping Weight

STANDARDS: ETL electrical & sanitation, cETL (Canada)

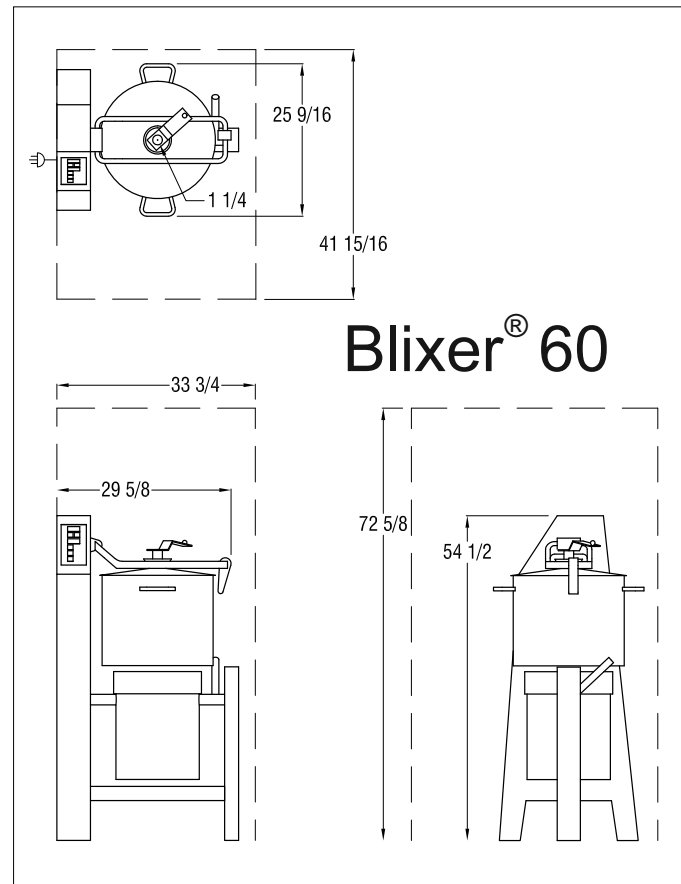
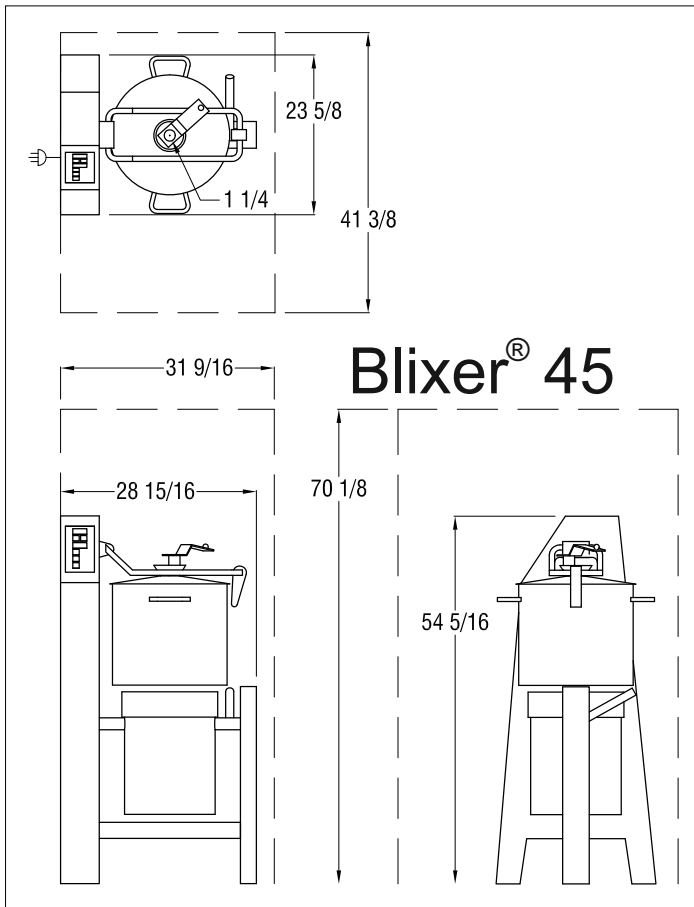

Robot Coupe U.S.A., Inc.
P.O. Box 16625
Jackson, MS 39236-6625
1-800-824-1646
(601) 898-8411
FAX: (601) 898-9134
www.robotcoupeusa.com
e-mail: info@robotcoupeusa.com

Distributed by: