

Continuous Feed Vegetable Prep



- Fan-cooled, heavy-duty, belt drive, 1.5 HP, Single phase motor.
- 39 available discs to select from.
- Has dicing and french fry capability.
- Attached large feed pusher assembly.
- Two deep feed openings.
- Automatic restart of machine with the half-moon shaped pusher.
- Attachments easily removed for maximum cleaning ability.
- Packed with two processing discs (28064 & 28058) as standard.
- 1 year parts and labor warranty.

Prepare 1200 servings in 3 hours or less.

Vegetable prep attachment designed for quality continuous feed slicing, dicing, shredding, grating, french fry, and julienne. Accommodates 39 different processing discs.



Robot Coupe U.S.A., Inc.
P.O. Box 16625
Jackson, MS 39236-6625
1-800-824-1646 • (601) 898-8411
FAX: (601) 898-9134
www.robotcoupeusa.com • e-mail: info@robotcoupeusa.com

SPECIFICATIONS ON REVERSE SIDE

Specifications

STANDARD MODEL: includes motor base unit with continuous feed attachment, one 1/8" (3mm) slicing disc and one 1/8" (3mm) medium grating disc.

ELECTRICAL REQUIREMENTS: 120V, 60Hz, 12 Amps, single phase, 1 speed., NEMA 5-15 plug.

SWITCHING: Control panel with push-type on and off buttons.

MOTOR: 1.5 HP, 425 RPM, belt drive, fan-cooled.

WEIGHT: 41 lbs. net, 45 lbs. approximate shipping weight.

OPTIONAL EQUIPMENT: 37 additional processing discs and single or multiple disc rack or wall-mounted disc rack.

PROCESSING DISCS		
* For Series D machines only		
<p>Slicing Discs</p> <p>28062 1/32" (1mm) 28063 5/64" (2mm) 28064 1/8" (3mm) 28004 5/32" (4mm) 28128* 3/16" (5mm) 28129* 5/16" (8mm) 28130* 3/8" (10mm) 28131* 9/16" (14mm) 28081 3/4" (19mm) 28132* 25/32" (20mm) 28133* 1" (25mm)</p> <p>Ripple Cut Slicers</p> <p>27068 5/64" (2mm) 27069 1/8" (3mm) 27070 3/16" (5mm)</p>	<p>Grating Discs</p> <p>28270 1/16" (1.5mm) 28057 5/64" (2mm) 28058 1/8" (3mm) 28073 5/32" (4mm) 28163 3/16" (5mm) 28164 9/32" (7mm) 28165 11/32" (9mm) 28055 Fine Pulping 28061 Hard Cheese Grate</p> <p>French Fry Kits</p> <p>28134* 5/16" (8mm) 28135* 3/8" (10mm)</p> <p>Romaine Lettuce Kit</p> <p>28133/104031 2"</p>	<p>Julienne Discs</p> <p>28051 5/64" x 5/64" (2mm x 2mm) 27072 5/64" x 5/32" (2mm x 4mm) 27066 5/64" x 1/4" (2mm x 6mm) 27067 5/64" x 5/16" (2mm x 8mm) 28052 5/32" x 5/32" (4mm x 4mm) 28053 1/4" x 1/4" (6mm x 6mm) 28054 5/16" x 5/16" (8mm x 8mm)</p> <p>Dicing Kits</p> <p>28110 3/16" x 3/16" (5mm x 5mm) 28111 5/16" x 5/16" (8mm x 8mm) 28112 3/8" x 3/8" (10mm x 10mm) 28113 9/16" x 9/16" (14mm x 14mm) 28114 25/32" x 25/32" (20mm x 20mm) 28115 1" x 1" (25mm x 25mm)</p>

STANDARDS: ETL electrical & sanitation, cETL (Canada)

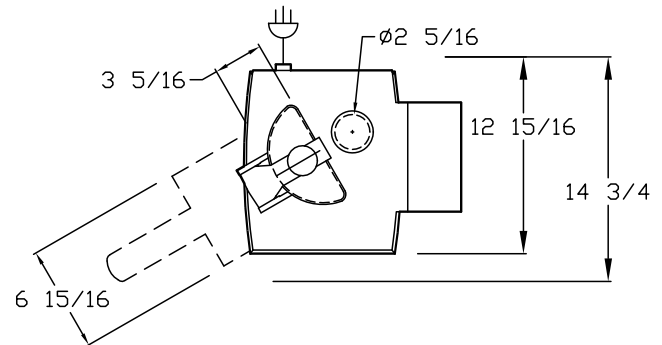
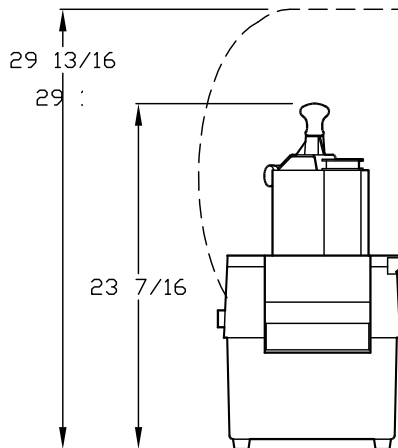
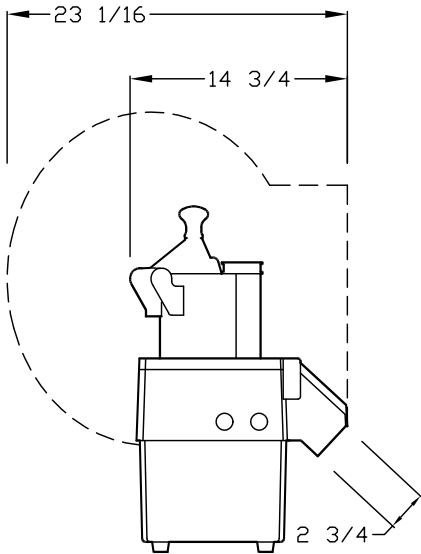

Robot Coupe U.S.A., Inc.
P.O. Box 16625
Jackson, MS 39236-6625
1-800-824-1646
(601) 898-8411
FAX: (601) 898-9134
www.robotcoupeusa.com
e-mail: info@robotcoupeusa.com

Distributed by: