

Dual- Purpose Food Processor with Mixer-Cutter Bowl Attachment and Continuous Feed Vegetable Prep Attachment



Prepare 800 servings in 2 1/2 hours or less.

Bowl attachment designed for vertical cutting and mixing: **mix, chop, puree and blend**. Vegetable prep attachment specially designed for quality continuous feed: **slicing, dicing, shredding, grating, french fry and julienne**. Accommodates 21 different processing discs, 2 french fry kits and 2 dicing kits.

- Direct drive, 2 H.P. , single phase motor with magnetic safety system and motor brake.
- Control panel with push button "On-Off" and pulse switches. Variable Speed control offers a range of 300 - 3600 rpm with cutter bowl and 300 - 1000 rpm with veg prep attachment.
- Standard Unit packed with two processing discs (27566, 4mm (5/32") slicing disc & 27577, 2mm (5/64") grating disc), 4 Qt. stainless steel cutter bowl with handle and stainless steel smooth edge "S" blade.
- Complete selection of 21 stainless steel discs, 2 french fry kits and 2 dicing kits are available.
- Attachments easily removed for easy cleaning and optimum sanitation.
- 1 year parts and labor warranty.



Robot Coupe U.S.A., Inc.

P.O. Box 16625

Jackson, MS 39236-6625

1-800-824-1646 • (601) 898-8411

FAX: (601) 898-9134

www.robotcoupeusa.com • e-mail: info@robotcoupeusa.com

SPECIFICATIONS ON REVERSE SIDE

Specifications

STANDARD MODEL: Includes motor base unit with continuous feed attachment, one 27566 - 5/32" (4mm) slicing disc and one 27577 5/64" (2mm) medium grating disc, 4 Qt. stainless steel cutter bowl with stainless steel smooth "S" blade.

ELECTRICAL REQUIREMENTS: 120V, 60Hz, 12 Amps, single phase. Contact your local electrician for local code requirements.

SWITCHING: Control panel with push-type on and off buttons with computerized variable speed control.

MOTOR: 2 HP, 300 - 3600 RPM, direct-drive, fan-cooled.

WEIGHT: 48 lbs. net, 50 lbs. approximate shipping weight.

Slicing Discs

- 27051 - 1/32" (1mm)
- 27555 - 5/64" (2mm)
- 27086 - 1/8" (3mm)
- 27566 - 5/32" (4mm)
- 27087 - 3/16" (5mm)
- 27786 - 1/4" (6mm)

Ripple Cut Slicers

- 27621 - 5/64" (2mm)

Graters

- 27588 - 1/16" (1.5mm)
- 27577 - 5/64" (2mm)
- 27511 - 1/8" (3mm)
- 27046 - 1/4" (6mm)
- 27632 - 11/32" (9mm)
- 27078 - Hard Cheese Grate

Pulping

- 27079 - Fine pulping disc
- 27764 - Pulping disc

Julienne

- 27599 - 5/64" (2x2mm)
- 27080 - 5/64" x 5/32" (2x4mm)
- 27081 - 5/64"x1/4" (2x6mm)
- 27047 - 5/32" (4x4mm)
- 27610 - 1/4" (6x6mm)
- 27048 - 5/16" (8x8mm)

French Fry Kits

- 27116 - 8x8 mm (5/16")
- 27117 - 10x10mm (3/8")

Dicing Kits

- 27113 - 8x8 mm (5/16")
- 27114 - 10x10mm (3/8")

OPTIONAL EQUIPMENT: 21 additional processing discs, 2 french fry kits, 2 dicing kits and single or multiple disc rack or wall-mounted disc rack.

STANDARDS: ETL electrical & sanitation, cETL (Canada)

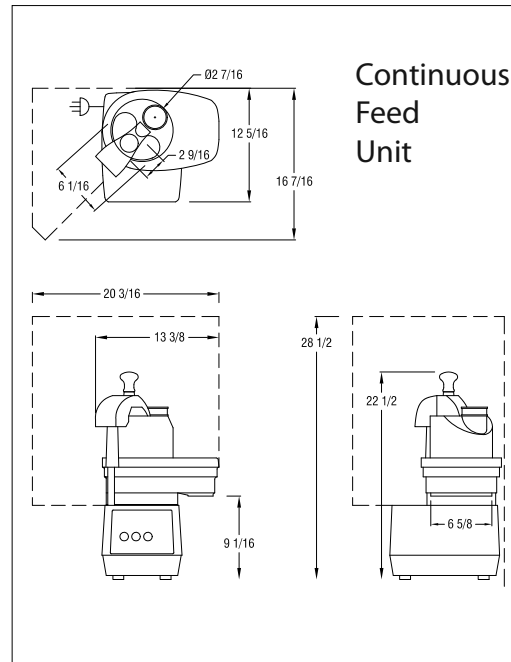
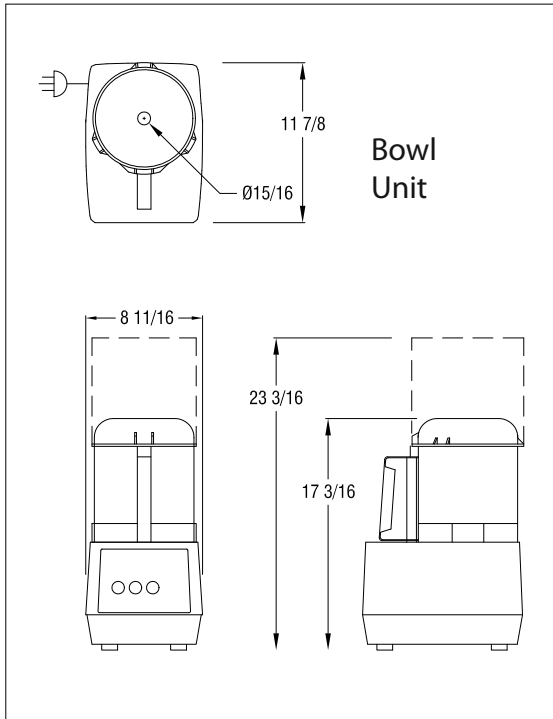

Robot Coupe U.S.A., Inc.
 P.O. Box 16625
 Jackson, MS 39236-6625
 1-800-824-1646
 (601) 898-8411
 FAX: (601) 898-9134
 www.robotcoupeusa.com
 e-mail: info@robotcoupeusa.com

Distributed by: